



DISPENSERS



PUMPS



METERS



NOZZLE



FILTRATION



FLUID  
MONITORING

# DRUM

## FEATURES

- EASY TO INSTALL
- SUITABLE FOR ALL DRUMS
- DIFFERENT PUMPS FOR ANY NEED
- AC/DC VERSIONS

The PIUSI DRUM is a compact fuel transfer unit suitable to be connected on drums thanks to the quick 2" coupling. Available with different pumps, the system is (always) equipped with a telescopic suction hose and the nozzle holder located above the drum, near the pump, for easy, clean and safe operations. K33 mechanical meter available on request.

## PERFORMANCE

UP TO

**80 L/MIN**

FLOW-RATE

**AC/DC**

VOLTAGE

POWER

**± 1%**

ACCURACY



DRUM BI-PUMP 12V



DRUM PANTHER 56 K33

## PACKAGING

CODE		WEIGHT		PACKAGING		
WITHOUT METER	WITH METER	KG	LBS	MM	INCH	PCS/BOX
OOO271POO	OOO272POO	13,5	29,8	480X370X265	18,3X14,6X10,4	1
OOO273POO	OOO274POO	14,4	31,7	480X370X265	18,3X14,6X10,4	1
FOO22201A	FOO22205A	20,7	45,6	480X370X265	18,3X14,6X10,4	1
FOO22202A	FOO22206A	20,7	45,6	480X370X265	18,3X14,6X10,4	1
FOO22203A	FOO22207A	21,6	47,6	480X370X265	18,3X14,6X10,4	1
FOO22204A	FOO22208A	21,6	47,6	480X370X265	18,3X14,6X10,4	1
-	FOO34111C	14,7	31,7	480X370X265	18,3X14,6X10,4	1



HOSE REELS



ACCESSORIES



MERCHANDISE



AIR



ANTIFREEZE



AdBlue®



BIODIESEL



DIESEL



FOOD



GASOLINE



GREASE



KEROSENE



OIL



WATER



WINDSCREEN

## CHART

### PUMPS

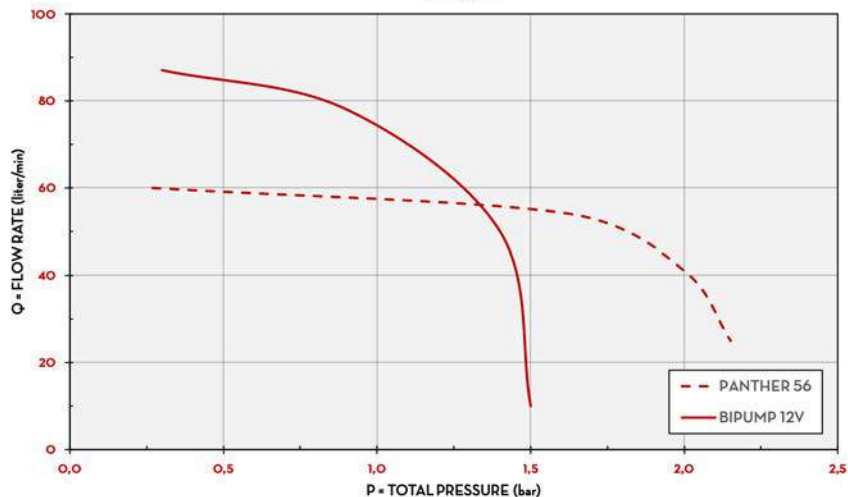

TYPE OF FLUID DIESEL

TEMPERATURE 9-10 °C

## IN THE BOX

- PUMP DRUM UNIT
- TELESCOPIC SUCTION PIPE
- DELIVERY HOSE
- NOZZLE
- 2" CONNECTOR
- K33 MECHANICAL METER (ON REQUEST)
- INSTRUCTION MANUAL

## DETAILS



2" CONNECTOR



TELESCOPIC SUCTION HOSE



ELECTRIC CABLE WITH CLAMPS (only dc version)

## DIMENSIONS

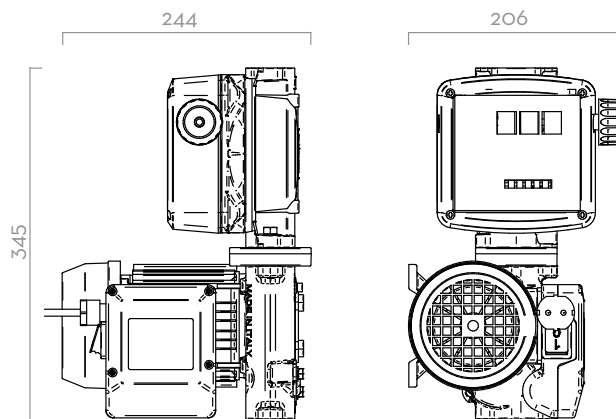

Dimensions expressed in millimeters

## COMPONENTS

- DEPENDING ON PUMP MODEL, SEE REFERRED PAGES.

## TECHNICAL DATA

CODE		DESCRIPTION	FLUIDS TYPE	FLOW-RATE		VOLTAGE			METER	NOZZLE	INLET	HOSE
WITHOUT METER	WITH METER			L/MIN	GPM	AC V./HZ DC VOLT	POWER WATT	AMP. MAX.				
000271POO	000272POO	DRUM PANTHER 56	D	56	15	230/50	350	3	K33	MAN.	3/4"	4M
000273POO	000274POO	DRUM PANTHER 56 A60	D	56	15	230/50	350	3	K33	AUT.	3/4"	4M
FO022201A	FO022205A	DRUM BI-PUMP 12V	D	80	21	12V	530	44	K33	MAN.	1"	4M
FO022202A	FO022206A	DRUM BI-PUMP 24V	D	80	21	24V	540	22,5	K33	AUT.	1"	4M
FO022203A	FO022207A	DRUM BI-PUMP 12V A120	D	80	21	12V	530	44	K33	AUT.	1"	4M
FO022204A	FO022208A	DRUM BI-PUMP 24V A120	D	80	21	24V	540	22,5	K33	MAN.	1"	4M
-	FO034111C	DRUM PANTHER DC 24/12V K33 A60	D	56	15	24/12V	150	25/16A	K33	AUT.	3/4"	4M