



DISPENSERS



PUMPS



METERS



NOZZLE



FILTRATION



FLUID MONITORING

EX50 DRUM

FEATURES

- STURDY STRUCTURE
- FLANGED COMPONENTS
- ANTI-NOISE FILTER
- THERMAL PROTECTION
- BUILT-IN BYPASS VALVE
- SUCTION PIPE WITH INTEGRATED FILTER
- UL LISTED VERSION AVAILABLE

The PIUSI EX50 DRUM is a complete pump transfer kit expressly engineered for ATEX/IECEx areas. This system is composed of a high-efficiency pump, manual or automatic nozzle and a telescopic suction hose. Thanks to the flanged components, this transfer set allows users to replace any component without using sealants thus creating maximum versatility and adaptability to any kind of condition. K33 mechanical meter available on request.



PIUSI DRUM EX50 WITH METER AND FILTER



DRUM EX50 WITH AUTOMATIC NOZZLE



DRUM EX50 WITH MANUAL NOZZLE

OUR PUMPS COMPLIES WITH THE FOLLOWING MARKING ATEX/IECEx

II	2	G	Ex	d	IIA	T4	Gb
GROUP	CATEGORY	TYPE OF EXPLOSIVE ATMOSPHERE	PERMANENT PREFIX	PROTECTION METHOD	GAS GLASS	TEMPERATURE CLASS	EQUIPMENT PROTECTION LEVEL

PACKAGING

CODE	WEIGHT		PACKAGING		
	KG	LBS	MM	INCH	PCS/BOX
WITHOUT METER					
FO0372000	10	22	600X400X290	23,6X13,7X11,4	1
FO0372010	10	22	600X400X290	23,6X13,7X11,4	1
FO0372020	79	17,4	345X175X225	-	1
FO0372030	10	22	600X400X290	23,6X13,7X11,4	1
FO0372040	10	22	600X400X290	23,6X13,7X11,4	1
FO037400A	10	22	600X400X290	23,6X13,7X11,4	1
FO037401A	10	22	600X400X290	23,6X13,7X11,4	1
FO037402A	79	17,4	345X175X225	-	1
WITH METER					
FO037500A	12	22	600X400X290	23,6X13,7X11,4	1
FO037501A	12	22	600X400X290	23,6X13,7X11,4	1
FO037502A	12	22	600X400X290	23,6X13,7X11,4	1
FO037503A	12	22	600X400X290	23,6X13,7X11,4	1
FO037600B	12	22	600X400X290	23,6X13,7X11,4	1
FO037601B	12	22	600X400X290	23,6X13,7X11,4	1

PERFORMANCE

UP TO
50 L/MIN

FLOW RATE

1100 MM

SUCTION PIPE

200β/30μ

FILTERING CAPACITY

± 1%

ACCURACY





HOSE REELS



ACCESSORIES



MERCHANDISE



AIR



ANTIFREEZE



AdBlue®



BIODIESEL



DIESEL



FOOD



GASOLINE



GREASE



KEROSENE



OIL



WATER

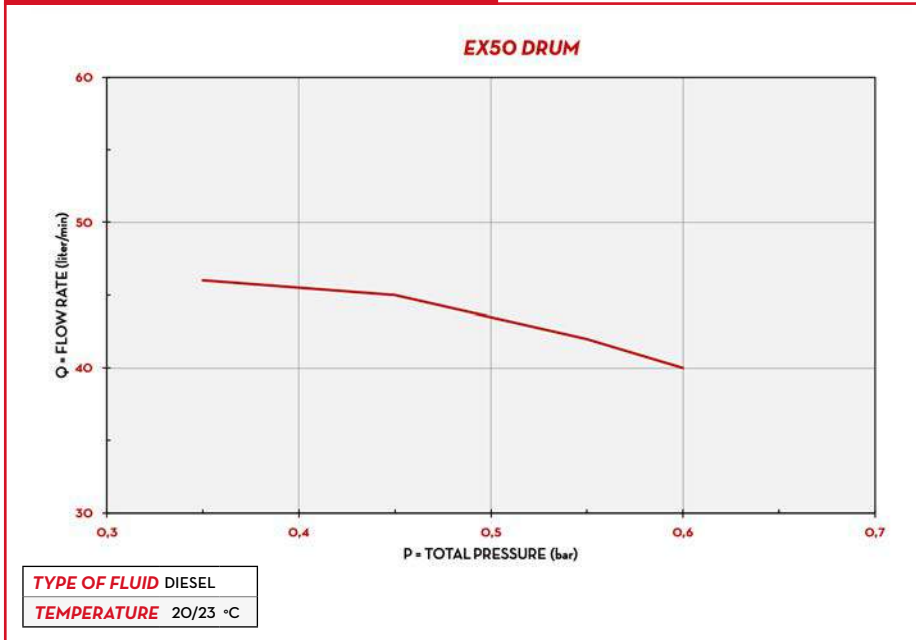

WINDSCREEN

CHART**IN THE BOX**

- EX50 PUMP
- TELESCOPIC SUCTION PIPE
- DELIVERY HOSE
- WATER CAPTOR FILTER
- NOZZLE
- 2" CONNECTOR
- K33 MECHANICAL METER (ON REQUEST)
- INSTRUCTION MANUAL

DETAILS

2" CONNECTOR



INTEGRATED FILTER

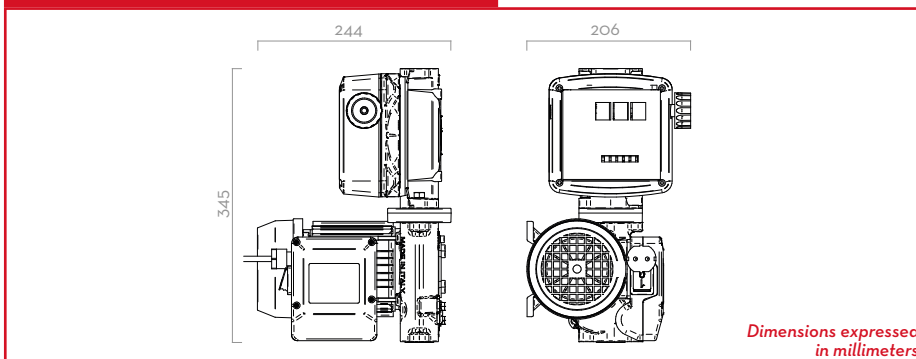

BENDING PROTECTION

DIMENSIONS**COMPONENTS**

- **PUMP:**
EX50 PAG. 58
- **METER:**
K33 ATEX PAG. 90
- **NOZZLE:**
A60 ATEX PAG. 116
SELF3000 PAG. 122
- **FILTER:**
WATER CAPTOR PAG. 128

TECHNICAL DATA

CODE	DESCRIPTION	FLUIDS TYPE	FLOW-RATE		VOLTAGE			METER	NOZZLE	FILTER	INLET	HOSE	
			L/MIN	GPM	AC V/HZ	DC VOLT	POWER WATT					AMP. MAX.	TYPE
WITHOUT METER													
FO0372000	DRUM EX50 12V DC ATEX + MAN. NOZZLE	D G K	50	13	12	250	21	-	MAN.	YES	1"	4	3/4"
FO0372010	DRUM EX50 12V DC ATEX + AUT. NOZZLE	D G K	50	13	12	250	21	-	AUT.	YES	1"	4	3/4"
FO0372020	KIT DRUM EX50 12V DC ATEX	D G K	50	13	12	250	21	-	NO	NO	1"	-	-
FO0372030	DRUM EX50 12V DC ATEX + MAN. NOZZLE + CABLE	D G K	50	13	12	250	21	-	MAN.	YES	1"	4	3/4"
FO0372040	DRUM EX50 12V DC ATEX + AUT. NOZZLE + CABLE	D G K	50	13	12	250	21	-	AUT.	YES	1"	4	3/4"
FO037400A	DRUM EX50 230V DC ATEX + MAN. NOZZLE	D G K	50	13	230/50-60	250	1	-	MAN.	YES	1"	4	3/4"
FO037401A	DRUM EX50 230V DC ATEX + AUT. NOZZLE	D G K	50	13	230/50-60	250	1	-	AUT.	YES	1"	4	3/4"
FO037402A	KIT DRUM EX50 230V AC ATEX*	D G K	50	13	230/50-60	250	1	-	NO	NO	1"	-	-
WITH METER													
FO037500A	DRUM EX50 12V DC K33 ATEX + MAN. NOZZLE	D G K	50	13	12	250	21	K33	MAN.	YES	1"	4	3/4"
FO037501A	DRUM EX50 12V DC K33 ATEX + AUT. NOZZLE	D G K	50	13	12	250	21	K33	AUT.	YES	1"	4	3/4"
FO037502A	DRUM EX50 12V DC K33 ATEX + MAN. NOZZLE + CABLE	D G K	50	13	12	250	21	K33	MAN.	YES	1"	4	3/4"
FO037503A	DRUM EX50 12V DC K33 ATEX + AUT. NOZZLE + CABLE	D G K	50	13	12	250	21	K33	AUT.	YES	1"	4	3/4"
FO037600B	DRUM EX50 230V DC K33 ATEX + MAN. NOZZLE	D G K	50	13	230/50-60	250	1	K33	MAN.	YES	1"	4	3/4"
FO037601B	DRUM EX50 230V DC K33 ATEX + AUT. NOZZLE	D G K	50	13	230/50-60	250	1	K33	AUT.	YES	1"	4	3/4"

(*) UPON REQUEST IT IS AVAILABLE WITH DIFFERENT VOLTAGES AND 60 HZ FREQUENCY.
COMPATIBLE FLUIDS: DIESEL, KEROSENE, PETROL, PETROL ALCOHOL MIXED MAX 15%, AVGAS 100/100LL, JET A/A1 - ASPEN 2/4

EX50 DRUM