



DISPENSERS



PUMPS



METERS



NOZZLE



FILTRATION



FLUID
MONITORING

PANTHER DC

FEATURES

- STURDY STRUCTURE
- EASY TO INSTALL
- COMPACT DESIGN
- IP55

The PANTHER DC is a rotary, self-priming vane pump suitable for all applications in which important flow rates are required. This equipment is fitted with an incorporated filter (100µ) and by-pass valve. The 24/12 V version can be used with both voltages.

PERFORMANCE

UP TO

70 L/MIN

FLOW-RATE

12/24V

VOLTAGE

POWER

30 MIN

DUTY CYCLE



PANTHER DC



PACKAGING

CODE	WEIGHT		PACKAGING		
	KG	LBS	MM	INCH	PCS/BOX
FO034000B	7,5	16,5	345X175X255	13,6X6,9X10	1
FO034001B	7,5	16,5	345X175X255	13,6X6,9X10	1
FO034100C	7,5	16,5	345X175X255	13,6X6,9X10	1
FO034101C	7,5	16,5	345X175X255	13,6X6,9X10	1
FO034116C	7,5	16,5	345X175X255	13,6X6,9X10	1



HOSE REELS



ACCESSORIES



MERCHANDISE

PIUSI

AIR



ANTIFREEZE



AdBlue®



BIODIESEL



DIESEL



FOOD



GASOLINE



GREASE



KEROSENE



OIL



WATER

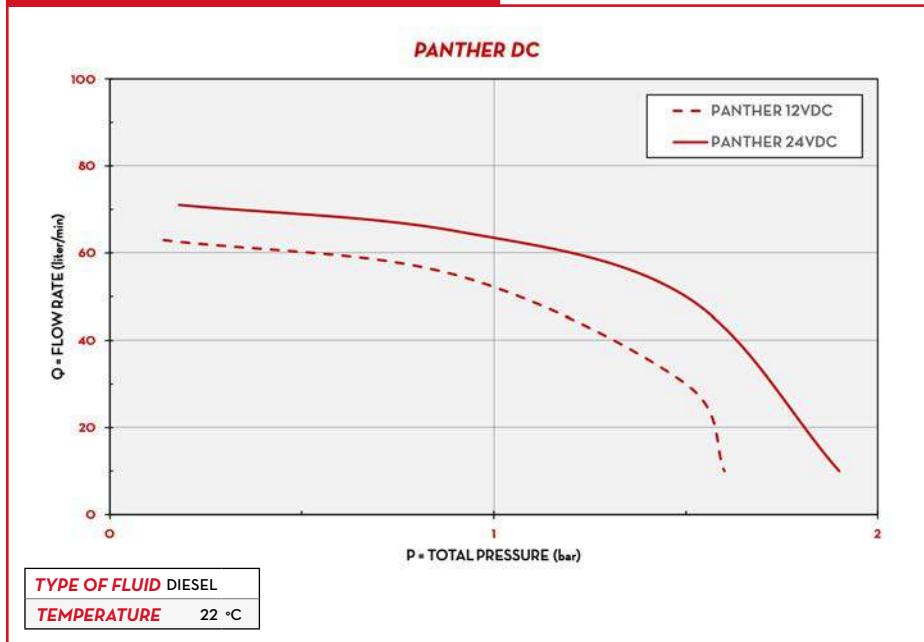

WINDSCREEN

CHART**IN THE BOX**

- PANTHER DC PUMP
- INSTRUCTION MANUAL

DETAILS

ON/OFF SWITCH



1" BSP THREADED

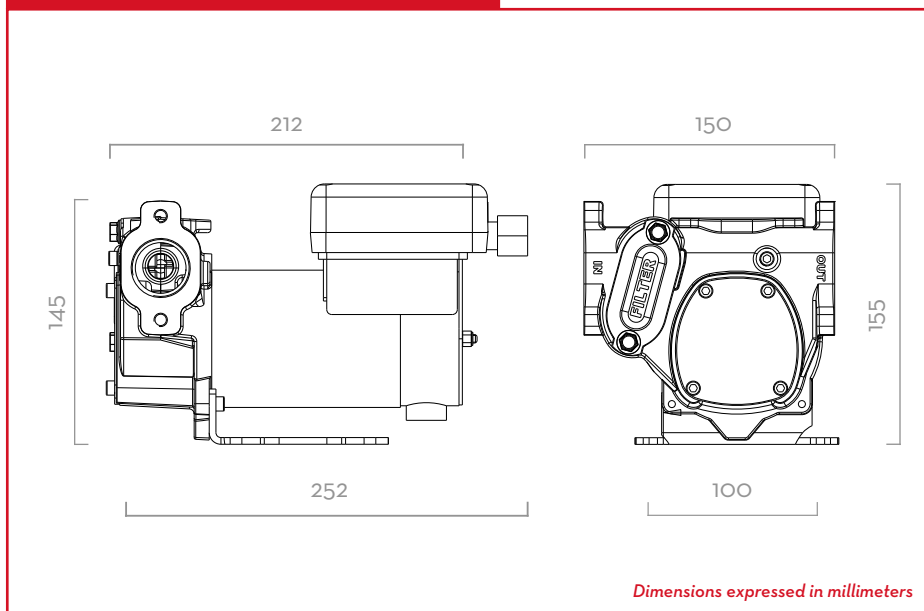

INTEGRATED FILTER

DIMENSIONS**MATERIALS**

- BODY: CAST IRON
- ROTOR: SINTERED STEEL
- VANES: ACETAL RESIN
- MOTOR: ALUMINIUM CASING

**PUMP**

- MAX 6M (20FT),
- SUCTION HOSE Ø 1" MIN,
- MAX SUCTION HEIGHT:
 - 2M (7FT) W/O NON RETURN VALVE
 - 4M (14FT) W NON RETURN VALVE

**TANK****TECHNICAL DATA**

CODE	DESCRIPTION	FLUIDS TYPE	FLOW-RATE		VOLTAGE			DUTY CYCLE	RPM	INLET
			L/MIN	GPM	DC VOLT	POWER WATT	AMP. MAX.	MINUTES		BSP
FOO34000B	PANTHER DC 12V	D	56	14,8	12	300	35	30	2900	1"
FOO34001B	PANTHER DC 12V W/CABLE 2M W/PLIERS	D	56	14,8	12	300	35	30	2900	1"
FOO34100C	PANTHER DC 24/12V	D	70 / 35	18,5 / 9,2	24/12	420 / 150	25 / 16	30	3600 / 1800	1"
FOO34101C	PANTHER DC 24/12V W/CABLE 2M	D	70 / 35	18,5 / 9,2	24/12	420 / 150	25 / 16	30	3600 / 1800	1"
FOO34116C	PANTHER DC 24/12V W/CABLE 4M W/PLIERS	D	70 / 35	18,5 / 9,2	24/12	420 / 150	25 / 16	30	3600 / 1800	1"

PANTHER DC

DC PUMPS

79